

# GS PRO

## MAKING THE LOAD LIGHTER

The GS Pro Series is an excellent tool for lifting and carrying loads on pallets or size-standardised containers. Thanks to its light weight, smooth movement and manoeuvrability, all the GS Series models are an ideal working tool for use on smooth floors and other kinds of surfaces.



### Maximum pressure valve

- When maximum load capacity is exceeded, the oil pressure exceeds its maximum limit and the valve automatically stops the forks from lifting. This prevents possible structural damage.

**Q = 3000 Kg.**  
**6600 lb.**

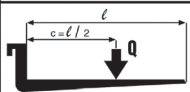

### 3 ton capacity

- The G530 has a reinforced structure that is extremely resistant to working stress, ensuring versatile and safe handling.



CAPACITY 2.5 t / 3.0 t



### Rollers

- Supplementary rollers allow an easier entrance and a quicker exit from a closed pallet, reducing the impact on the main rollers and guaranteeing a longer life.



### Wheels

- The hand pallet trucks of this series have big wheels (Ø200x55 mm) to reduce handling effort.

MODEL		25 52	25 - 30 54	25 52	25 - 30 54	25 52	25 - 30 54	25 52	25 - 30 54	25 52	25 - 30 54
CAPACITY	kg	2500	2500/3000	2500	2500/3000	2500	2500/3000	2500	2500/3000	2500	2500/3000
ROLLERS	N°/*	2/N	4/N	2/N	4/N	2/N	4/N	2/N	4/N	2/N	4/N
WHEELS	*	P	P	P	P	P	P	P	P	P	P
<b>DIMENSIONS</b>											
FORK LENGTH	mm	1150	1150	800	800	950	950	1000	1000	1220	1220
FORK WIDTH	mm	525	525	525	525	525	525	525	525	525	525
HEIGHT FROM THE FLOOR MIN/MAX	mm	85/200	85/200	85/200	85/200	85/200	85/200	85/200	85/200	85/200	85/200
WEIGHT	kg	61	63/79	55	57/68	57	59/73	58	60/74	63	65/80
<b>OPTIONALS</b>											
ROLLERS IN POLYURETHANE											
WHEELS IN RUBBER											
HAND OPERATED BRAKE											

\* P=Polyurethane, N=Nylon

	mm	800	950	1000	1150	1220
I	mm	800	950	1000	1150	1220
I1	mm	679	829	879	1029	1099
I2	mm	450	600	650	800	870
I3	mm	627	777	827	977	1047
I4	mm	500	650	700	850	920
L	mm	1200	1350	1400	1550	1620
Wa	mm	1019	1168	1218	1367	1437
Asf	mm	1484	1633	1683	1832	1902

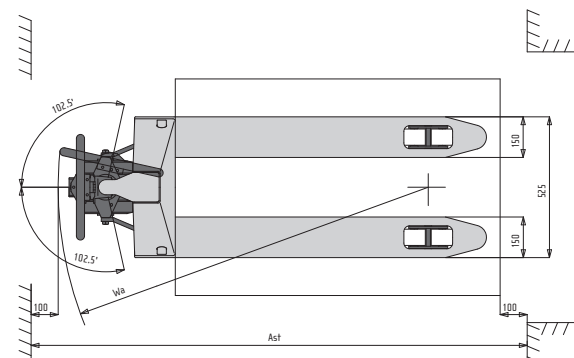
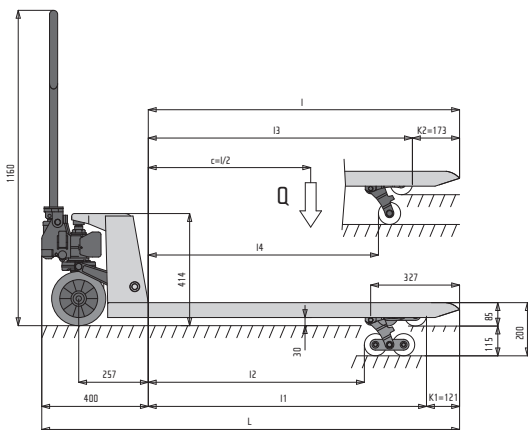

The producer reserves the right to introduce changes to models and features without prior notice.